

尾 座

NC旋转工作台对应表

尾座型号	手动	油压	空压
NC旋转工作台 型号			
RN-100	TL-110M	—	—
RWE/RWA-160	TL-135M	TLH-135	TLP-135
RBS-160 RWE/RWA-200, RWA-250 RNCM-251 RBA-250	TL-160M	TLH-160	TLP-160
RBS-250 RWA-320 RNCM-301 RBA-320, RBA-320K	TL-210M	TLH-210	—
RBS-320 RNCM-401 RBA-400K	TL-255M	TLH-255	—
RNCM-501	TL-310M	—	—
RNCM, RNCK-631	TL-400M	—	—
RCV-800	TL-530M	—	—
THNC-251	TL-210M	TLH-210	—
THNC-301	TL-235M	—	—

型 号

T L - 1 6 0 M

中心高度

记号	型 号
无	手 动
H	油 压
P	空 压

使用空压尾座实例

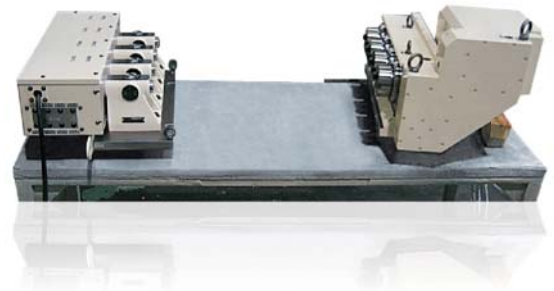

手动尾座

TL-110M, 135M



照片为TL-135M

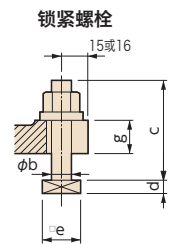
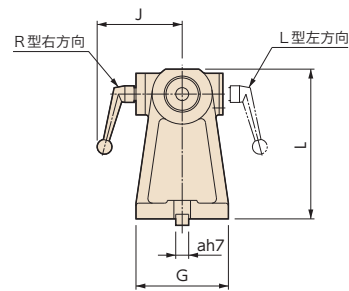
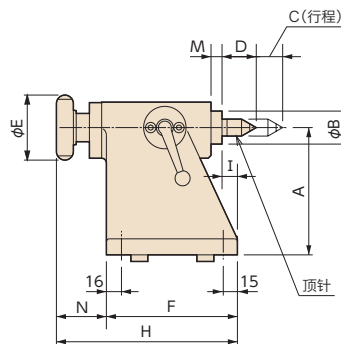

TL-□□□M



照片为TL-160M

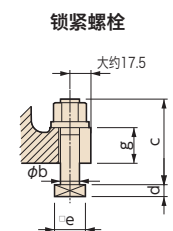
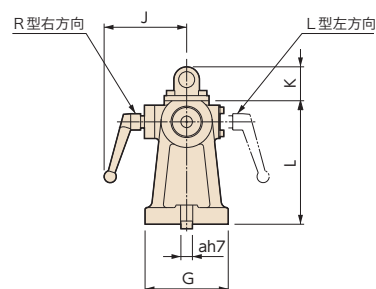
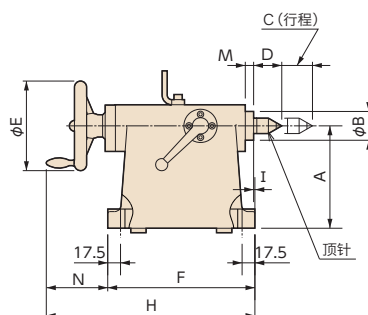

RBS

TBS

RWE/RWA
RN

RWE/RWA-B
RNCV-B

RNCM

RBA

RBA-K
RNCK

RCH
RNC

RCV
RNCV

RN-N
(多轴)

TWA/TN

TTNC

THNC

TTNC-N
(多轴)

RC
RH

RUA

TSUA

RDS

RTV
RTT

RCB

单轴NC
控制器

附件

选项

资料